

# FPM-8192V

## 19" SXGA Transflective Marine Grade Monitor with Resistive Touchscreen

NEW



### Features

- 19" SXGA TFT LCD with transflective technology for outdoor visibility
- Dimming knob controls backlight brightness from nearly 0% to 100%
- Front OSD control with PIP (picture in picture) function
- Wide voltage power input 24 V<sub>DC</sub>
- Direct-VGA, DVI-D, Video & S-Video input interface
- Chassis ESD/grounding protection
- Robust design with anti-rust aluminum housing and IP65 complaint front panel
- DNV standard 2.4 certified and IEC-60945 & IACS-E10 approved
- Front access mounting mechanism for marine bridge systems

### Introduction

FPM-8192V is a 19" SXGA monitor with transflective display & dimming knob control from 0% ~ 100%, designed for marine industry applications. Constructed from marine grade aluminum with a UV protected powder coating, FPM-8192V ensures reliability even in harsh outdoor conditions. FPM-8192V can also accept up to 4 common video inputs, including VGA, DVI, S-Video, and Video as well as three stage PIP (picture in picture) with floating and resizable windows. Advantech's marine display is the right choice for any marine application due to its ease of installation, outstanding viewing capabilities and reliability.

### Specifications

#### General

- **Button Controls** Front OSD control pad with dimming control knob
- **Certifications** CE, FCC, DNV, IEC 60945, IACS-E10
- **Dimensions (W x H x D)** 483 x 444 x 75 mm (19" x 17.48" x 1.95")
- **Enclosure** Aluminum with coating
- **Mounting** Panel
- **Power Input** 45 W, 24 V<sub>DC</sub>, 2.5 A
- **Video Port** VGA, DVI-D, Composite Video, S-Video
- **Weight** 14.5 kg (31.96 lbs)

#### LCD Display

- **Display Type** SXGA TFT LCD with transflective display
- **Display Size** 19"
- **Max. Resolution** 1280 x 1024
- **Max. Colors** 16.7M
- **Luminance (cd/m<sup>2</sup>)** 500 under ambient lighting 10,000 nits  
630 under ambient lighting 30,000 nits  
830 under ambient lighting 80,000 nits
- **Viewing Angle (H/V°)** 140/135
- **Backlight Life (hrs)** 50,000
- **Contrast Ratio** 550:1

#### Touchscreen (Optional)

- **Sensor** ELO
- **Driver** ELTOUCH
- **Lifespan** 35 million touches at single point
- **Light Transmission** Above 75%
- **Resolution** Linearity
- **Type** 5-wire, analog resistive
- **OS** Windows 2000/XP/CE/Vista, Linux
- **Power Consumption** +5 V @ 100 mA

#### Environment

- **Operating Temperature** -10 ~ 55° C (14 ~ 131° F)
- **Storage Temperature** -40 ~ 70° C (-40 ~ 140° F)
- **Humidity (Storage)** 100% non-condensing
- **Waterproof Front Panel** IP65, IP54 rear cover
- **Vibration** Frequency range: 3 ~ 13.2 Hz,  
Amplitude: 1.0mm (peak value)  
Frequency range: 13.2 ~ 100 Hz,  
Acceleration amplitude: 0.7g

### Ordering Information

- **FPM-8192V-X0AE** 19" SXGA Marine Grade Monitor
- **FPM-8192V-R1AE** 19" SXGA Marine Grade Monitor w/TS (RS-232)

### Dimensions

Unit: mm

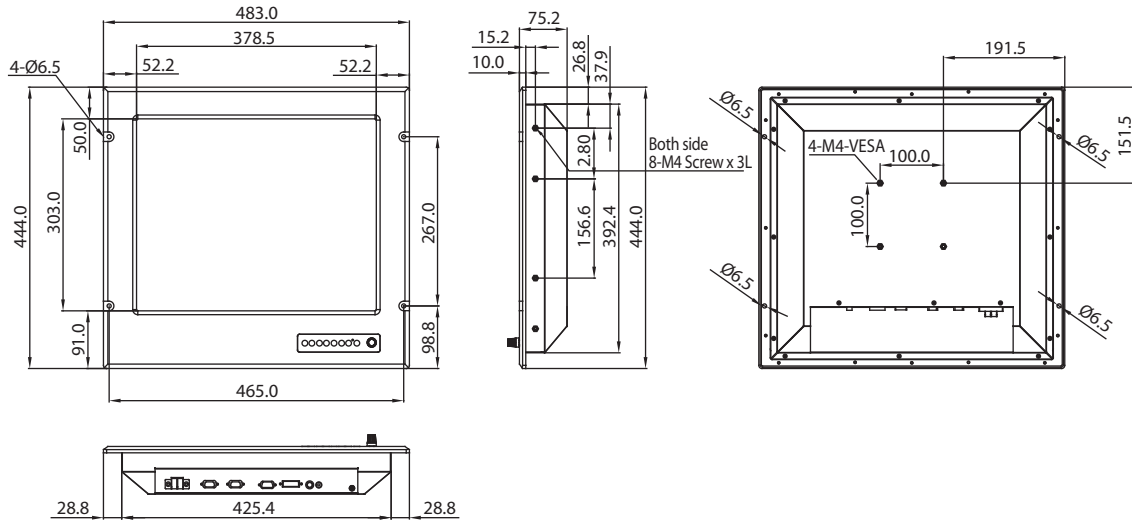

Panel Cut-out Dimensions: 429 x 396 mm

### Front View (Panel Mount)



### I/O View

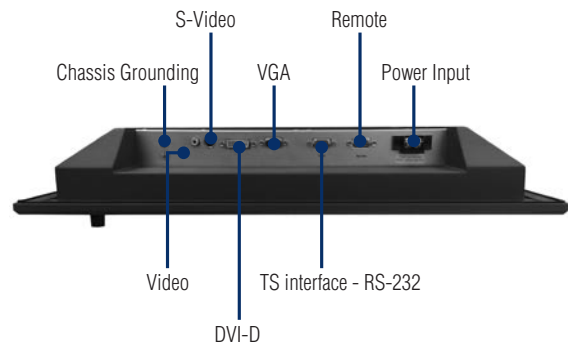

### Front OSD with Dimming Knob

